

KOBELCO

ED160 *BLADE RUNNER*

■ Bucket Capacity :

0.5 m³ ISO heaped

■ Engine Power :

78.5 kW/2,000 min⁻¹ (ISO14396)

■ Operating Weight :

16,300 kg



Power Meets Efficiency

Productive Digging and Large-Capacity Dozing

ED160 *BLADE
RUNNER*

KOBELCO





Fit a hydraulic excavator with a large, tilt-angle dozer blade for great performance both digging and dozing— that's the ED160 Blade Runner. Using one machine to cover a whole range of jobs including leveling, digging, pipe laying and backfilling, gives a massive boost in productivity. The tilt-angle blade allows leveling and backfilling on irregular ground.

The ED160 Blade Runner features the worry-free SR short rear swing specs, and it has built-in toughness to handle the double tasks of dozing and digging. Its iNDR noise and dust control system cuts engine noise and simplifies maintenance.

Add to that a well-equipped, comfortable cab. Giving fast, efficient digging and large capacity dozing, this one machine is versatility itself on site.



Revolutionary Double Offset Duct Design Cuts Engine Noise

By redesigning the iNDR configuration KOBELCO has come up with a stylish machine with great visibility from the cab, despite the larger engine compartment needed to ensure compliance with TIER IV Final emission standards.

The iNDR system absorbs sound energy by sealing the engine compartment and channeling air to cool the engine through a complex duct. Now equipped with a selective catalytic reduction (SCR) unit for cleaner emissions, the new model features two offset ducts with ample capacity to absorb engine noise, for a much quieter machine.



The Results Are Exceptional. The Big Merits:

“Ultimate Low Noise” achieved by minimizing sound leakage

Noise from the engine and cooling fan is absorbed by the duct, so the machine far surpasses legal requirements. Kobelco calls this system, which exceeds all noise standards, “Ultimate Low Noise,” and it reduces noise to 95dB(A).



Eliminating dust maintains cooling system performance

The high-density 60-mesh filter* traps dust from the intake air. The waveform filter allows air through the tops of the waves while concentrating dust at the bottom, ensuring smooth airflow. With no clogging, the cooling system and air cleaner easily maintain peak performance.

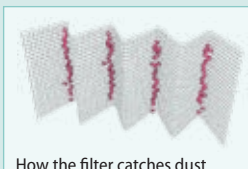

*“60-mesh” means that there are 60 holes formed by horizontal and vertical wires in every square inch of filter.

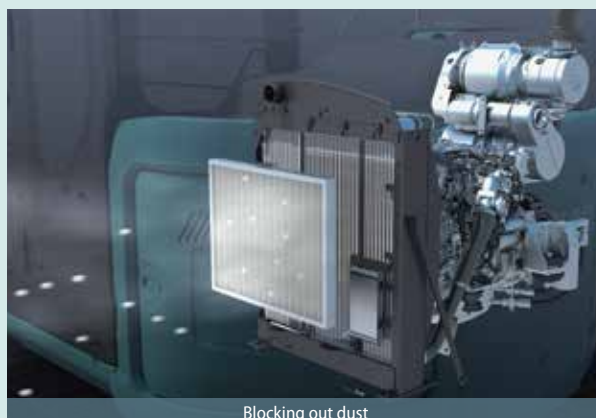

Easy filter cleaning simplifies maintenance

A simple daily visual check of the iNDR filter identifies when it requires cleaning. It is easily removed for washing without special tools.





Wide, clear view to the rear

Even with the larger engine compartment, the design minimizes hood height, ensuring an excellent direct view to the rear. In addition, the operator can monitor conditions behind the machine with clear, wide-angle images from the rear-view camera, which comes as standard equipment.



New Environmentally-Friendly Engine

New STAGE IV compliant engine NEW

The new type of STAGE IV Compliant engine is fitted with a diesel oxidation catalyst (DOC) and an SCR device to control emissions without using a diesel particulate filter (DPF). It has a large-capacity DEF/Urea tank, extending intervals between fill-ups.



■ NOx reduction rate
(Compared to previous models)

About **88%** decrease

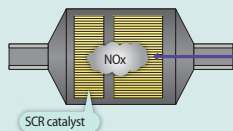

Newly developed engine raises the bar for construction machinery

The new ISUZU engine is renowned for its outstanding environmental performance, and has been tuned specifically for use in KOBELCO machines. This environmentally friendly engine changes conventional wisdom on balancing powerful performance with eco-friendliness. And eliminating the DPF makes maintenance faster and easier, too.

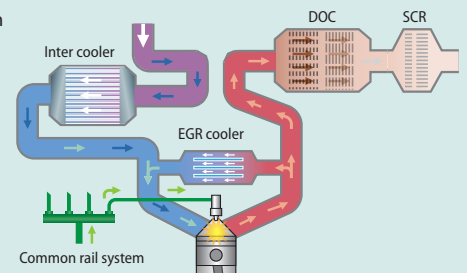

NOx emissions cut

At high temperatures, nitrogen and oxygen combine to produce nitrous oxides (NOx). Reducing the amount of oxygen and lowering the combustion temperature results in much less NOx.

EGR cooler

While ensuring sufficient oxygen for combustion, cooled emission gases are mixed with the intake air and re-circulated into the engine. This reduces oxygen content and lowers combustion temperature.

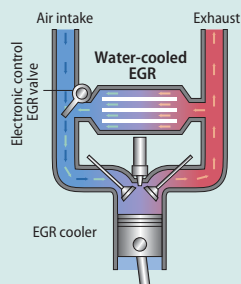

PM emissions cut

Particulate matter (PM) is mostly soot resulting from incomplete combustion; Improved combustion efficiency reduces PM emissions.

Common rail system

High-pressure injection atomizes the fuel, and more precise injection improves combustion efficiency. This also contributes to better fuel economy.

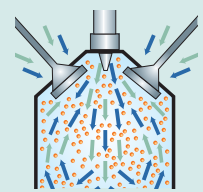

Common rail system

Unbeatable Cost Performance

Greater Work Capacity:
Exceeding Expectations in Productivity

Improved Fuel Efficiency Contributes to High Performance

Superior digging volume

This excavator offers dynamic digging force even as it minimizes fuel consumption rates, achieving class-leading work volume. H-mode with an increased torque setting delivers about 5.2% greater digging volume.

■ Digging volume/hour

(Compared to H-mode on previous models)



■ Max. bucket digging force

90.1 kN (ISO 6015)

■ Max. arm crowding force

64.4 kN (ISO 6015)



Energy-Efficient System

Eco-mode: engineered for economy

Kobelco's ECO-mode maximizes the operating efficiency of the engine and other components to achieve much greater fuel efficiency. Just press a button to choose the operation mode best suited to the task at hand and the working conditions

■ Optimal operation with three modes

- H** H-mode ••• Maximum power for maximum productivity on your toughest jobs
- S** S-mode ••• Ideal balance of productivity and fuel efficiency for a range of urban engineering projects
- E** ECO-mode ••• Minimum fuel consumption for utility projects and other work that demands precision

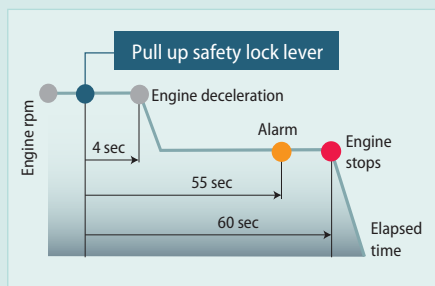

AIS (Auto Idle Stop)

If the safety lock lever is left up, the engine will stop automatically.

This eliminates wasteful idling during standby, saving fuel and reducing CO₂ emissions as well.

Hydraulic system engineered to reduce energy loss

Kobelco's proprietary hydraulic systems offer hydraulic line positioning that reduces friction resistance and valves designed for higher efficiency, minimizing energy loss throughout the system.

Dual Purpose from the Start

Large capacity dozing

ED160 Blade Runner is fitted with a large dozing blade 3,260 mm wide and 815 mm high, and can readily shift large volumes of earth, working to a height of 790 mm and a depth of 600 mm. With 196 kN of drawbar pulling force, the ED160 has the power to doze and backfill in all recommended operating positions.

Dimensions:

3,260 mm (width) x **815 mm** (height)

Working Ranges:

790 mm (height), **600 mm** (depth)

Drawbar Pulling Force: 196 kN

Dozer Capacity: 1.6 m³

Power, Angle and Tilt capability (PAT)



The 6-way dozer blade has Power, Angle and Tilt capability (PAT) operated from the cab. With a single control lever, the blade can be angled 25 degrees to the left or right for dispensing earth and materials away for the operator's path. The blade also tilts up on the left and right sides by 455 mm for slope grading, culverts and ditches.



Single dozer lever

A conveniently located single dozer lever controls all blade hydraulic function.

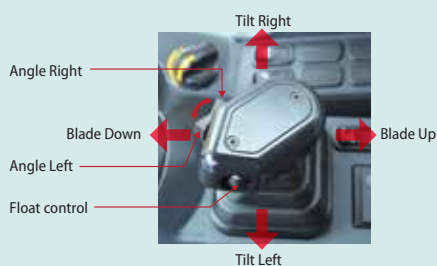

Exclusive dozer circuit

The dedicated dozer circuit has a relief valve setting of 27.4 MPa. Steady and powerful dozing is unaffected by digging, swinging, travel or other machine function.

Curved track shoes

The curved shape of the crawler shoes improves maneuverability with good grip and gives crisp travel minimizing damage to ground surfaces.

Plenty of ground clearance

Excellent ground clearance ensures unhindered travel.



Great swing power, short cycle times

Powerful swing power and top-class swing speed.

Swing Speed: 11.0 min⁻¹{rpm}

Swing Torque: 39.9 kN

Compact swing radius

Compact design ensures efficient operation on sites where space is limited.

Tail overhang:
190 mm



Cab Design That Puts the Operator First

Wide and open, the cab's interior overflows with features that streamline operation

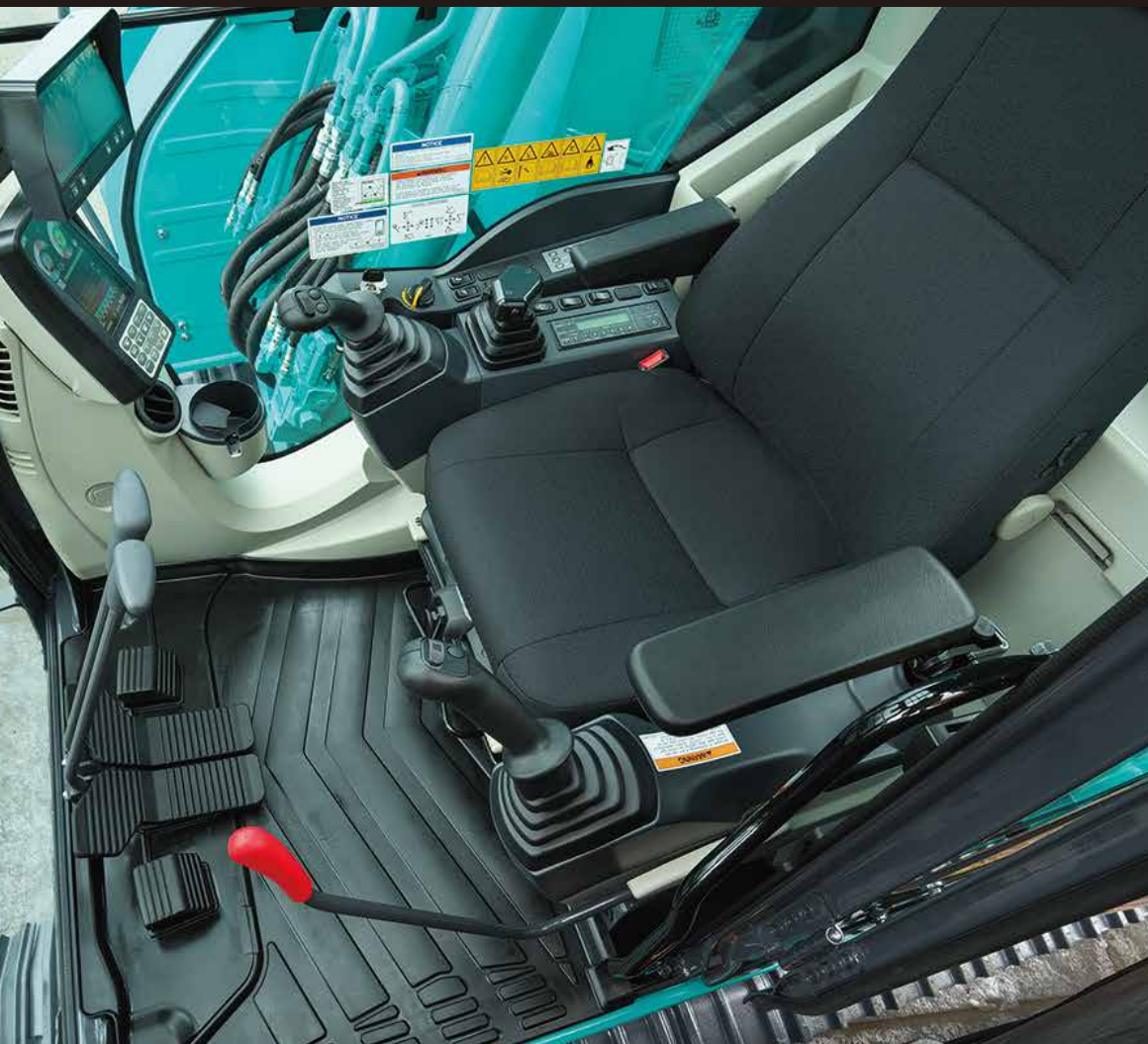

Comfort

Big roomy cab

The cube design makes the most of straight lines, so the cab interior is 4% more spacious than before. Operating space literally spreads out before the operator. And the 50 Pa airtightness keeps dust outside.



Wide-open field of view

On the right side, the large single window has no center pillar, and the whole cab is designed for a wide field of view, giving the operator a direct view ahead and to the left and right.

Wide doors and ample head clearance mean smooth entry and exit

The control box and safety lock lever tilt up at a larger angle, and the door handle height is positioned for easy cab entry and exit.



More comfortable seat means higher productivity

The cab interior offers a host of operator comforts. The seat guarantees comfort whether on the job or at rest, and everything is ergonomically planned and laid out for smooth, stress-free operation.



Seat suspension absorbs vibration



Seat recliner can be pushed back flat



Double slides allow adjustment for optimum comfort

Equipment designed for comfort and convenience



Bluetooth installed NEW

Bluetooth installed to allow connections with iPhones and other devices.



Powerful automatic air conditioner

Also standard is an automatic air conditioner that maintains a comfortable interior environment all year around.



Large cup holder



Spacious storage tray



USB/AUX



12V power outlet

Safety

ROPS cab

ROPS (Roll-Over-Protective Structure)-compliant cab clears ISO standards (ISO-12117-2: 2008) and ensures greater safety for the operator should the machine tip over.



Top Guard level II (Meets ISO10262)



Mounting brackets for vandalism guards are standard equipment (contact your KOBELCO dealer to fit vandalism or front rock guards)

Expanded field of view for greater safety



Left rear view mirror



Rear view from cab

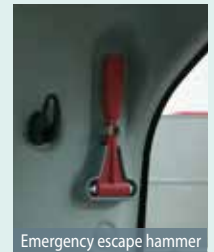

Emergency escape hammer

Right side camera fitted as standard NEW

Further to the existing rear-view camera, a camera for the right side is fitted as standard for easy safety checks all round the machine.

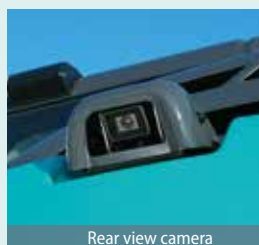

Rear view camera



Right side camera



Monitor Rear Right

Proper Maintenance Ensures Peak Efficiency

Kobelco machines are designed for quick, simple inspection and maintenance.



Machine Information Display Function

- Displays only the maintenance information that's needed, when it's needed
- Self-diagnostic function provides early-warning detection and display of electrical system malfunctions
- Service-diagnostic function makes it easier to check the status of the machine
- Record function of previous breakdowns including irregular and transient malfunction

Maintenance information display

Easy, on-the-spot maintenance NEW



Urea tank

Urea filler cap is placed on the step for easy access.



Engine maintenance

Setting up maintenance area one step down allows easy to access to the engine.



Handhold

The handrail is placed on the boom side. In addition, the distance between the current handrails was increased to allow easier access to the maintenance port on the upper arm.

Maintenance work, daily checks, etc., can be done from ground level

The layout allows for easy access from the ground for many daily checks and regular maintenance tasks.



Engine oil filter



Hydraulic pump



iNDR filter/radiator reservoir tank/air cleaner

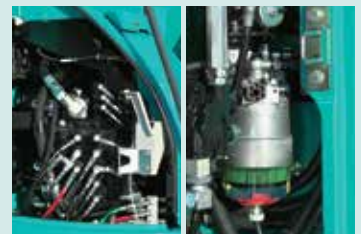

Control valve/water separator

Fast maintenance requires only a few procedures



Washer fluid tank is located under the cab floor mat.



Engine oil quick-drain valve can be turned without.



Fuel tank features bottom flange and large drain valve.

Quality that Keeps on Shining. Valuable Assets Take Your Business to the Next Level.

Structural strength and proven reliability mean these machines can deal with heavy work loads and perform in rigorous site environments. From the lifecycle viewpoint, these machines maintain their value throughout their service lives.



Improved Filtration System Reliability

Clean, contaminant-free fuel and hydraulic fluid are essential to stable performance. The improved filtration systems reduce the risk of mechanical trouble and enhance longevity and durability.

Hydraulic fluid filter **NEW**

Recognized as the best in the industry, our super-fine filter separates out even the smallest particles. New cover prevents contamination when changing filters.



Hydraulic fluid filter clog detector **NEW**

Pressure sensors at the inlet and outlet of the hydraulic fluid filter monitor differences in pressure to determine the degree of clogging. If the difference in pressure exceeds a predetermined level, a warning appears on the multi-display, so any contamination can be removed from the filter before it reaches the hydraulic fluid reservoir.

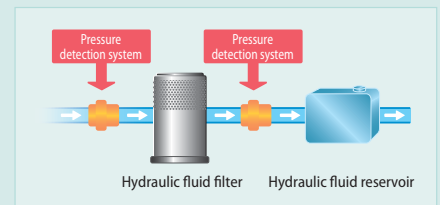

Enlarged fuel filter **NEW**

The enlarged fuel filter with built-in water separator maximizes filtering performance.

60%
enlarged

Easy cleaning saves time



Detachable two-piece floor mat has handles for easy removal. The mat's raised edges trap dirt and grit for easy cleaning.



Special crawler frame design makes it easy to clean off mud.



Double-element air cleaner

The large-capacity element features a double-filter structure that keeps the engine running clean even in industrial environments.

Long-life hydraulic oil:
5,000
hours

Long-interval maintenance

Long-life hydraulic oil reduces cost and labor.

Replacement cycle:
1,000
hours

Highly durable super-fine filter

The high-capacity hydraulic oil filter incorporates glass fiber with superior cleaning power and durability.

Comprehensive Safety and Intuitive Operation

User-friendly design and enhanced safety means greater efficiency and productivity.



Operator-friendly Features Include Controls that Are Easy to See, Easy to Use



Multi-display in color

Brilliant colors and graphic displays are easy to recognize on the LCD multi-display in the console. The display shows fuel consumption, maintenance intervals, and more.

- ① Analog gauge provides an intuitive reading of fuel level and engine water temperature
- ② Green indicator light shows low fuel consumption during operation
- ③ Urea tank level gauge
- ④ Fuel consumption
- ⑤ Digging mode switch
- ⑥ Monitor display switch

One-touch attachment mode switch

A simple flick of a switch converts the hydraulic circuit and flow amount to match attachment changes. Icons help the operator to confirm the proper configuration at a glance.



Urea accumulation display

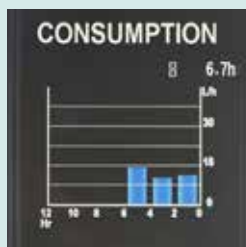

Fuel consumption



Maintenance

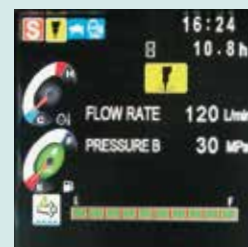

Breaker mode



Nibbler mode

KOMEXS

KOBELCO MONITORING EXCAVATOR SYSTEM



Remote monitoring for peace of mind

KOMEXS (Kobelco Monitoring Excavator System) uses satellite communication and internet to relay data, and therefore can be deployed in areas where other forms of communication are difficult. When a hydraulic excavator is fitted with this system, data on the machine's operation, such as operating hours, location, fuel consumption, and maintenance status can be obtained remotely.

Direct Access to Operational Status

Location data

Accurate location data can be obtained even from sites where communications are difficult.



Latest location



Location records



Work data

Operating hours

- A comparison of operating times of machines at multiple locations shows which locations are busier and more profitable.
- Operating hours on site can be accurately recorded, for running time calculations needed for rental machines, etc.



Daily report

Fuel consumption data

Data on fuel consumption and idling times can be used to indicate improvements in fuel consumption.

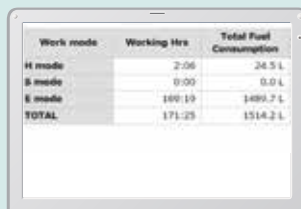

Fuel consumption

Graph of work content

The graph shows how working hours are divided among different operating categories, including digging, idling, travelling and optional operations.

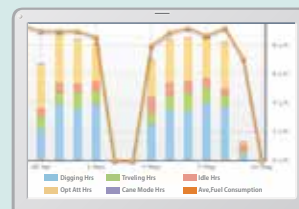

Work status

Maintenance Data and Warning Alerts

Machine maintenance data

- Provides maintenance status of separate machines operating at multiple sites.
- Maintenance data is also relayed to KOBELCO service personnel, for more efficient planning of periodic servicing.

Model	Serial No.	Hour Meter	Engine Oil
SK230RCLC	11012-00723	734 H	434
SK230RCLC	11012-00735	333 H	439
SK230RCLC	11012-00789	333 H	439
SK230RCLC	11012-00834	990 H	58
SK230RCLC	11012-00883	549 H	448
SK230RCLC	11012-00933		

Maintenance

Warning alerts

This system warns an alert if an anomaly is sensed, preventing damage that could result in machine downtime.

Alarm information can be received through E-mail

Alarm information or maintenance notice can be received through E-mail, using a computer or cell phone.



Alarm messages can be received on mobile device.

Daily/Monthly reports

Operational data downloaded onto a computer helps in formulating daily and monthly reports.

Security system

Engine start alarm

The system can be set an alarm if the machine is operated outside designated time.

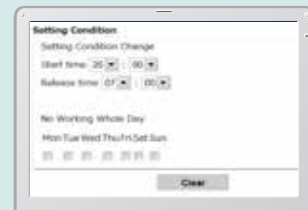

Engine start alarm outside prescribed work time

Area alarm

It can be set an alarm if the machine is moved out of its designated area to another location.



Alarm for outside of reset area

Engine

Model	ISUZU AR-4JJ1XASK-01
Type	Direct injection, water-cooled, 4cycle diesel engine with intercooler, turbocharger (complies with EU (NRMM) Stage IV)
No. of cylinders	4
Bore and stroke	95.4 mm x 104.9 mm
Displacement	2,999 L
Rated power output	71.3kW/2,000 min ⁻¹ (ISO 9249)
	78.5kW/2,000 min ⁻¹ (ISO 14396)
Max. torque	347N-m/1,800 min ⁻¹ (ISO 9249)
	375N-m/1,800 min ⁻¹ (ISO 14396)

Hydraulic System

Pump	
Type	Two variable displacement piston pumps + Two gear pumps
Max. discharge flow	2 x 130 L/min, 1 x 20 L/min, 1 x 55 L/min
Relief valve setting	
Boom, arm and bucket	34.3 MPa {350 kgf/cm ² }
Travel circuit	34.3 MPa {350 kgf/cm ² }
Swing circuit	28.0 MPa {285 kgf/cm ² }
Dozer circuit	27.4 MPa {280 kgf/cm ² }
Control circuit	5.0 MPa {50 kgf/cm ² }
Pilot control pump	Gear type
Main control valves	8-spool
Oil cooler	Air cooled type

Swing System

Swing motor	Axial piston motor
Parking brake	Oil disc brake, hydraulic operated automatically
Swing speed	11.0 min ⁻¹
Swing torque	39.9 kN-m
Tail swing radius	1,490 mm
Min. front swing radius	2,000 mm

Attachments

Backhoe bucket and combination

Use			Backhoe bucket							
			Normal digging							
Bucket capacity	ISO heaped	m ³	0.24	0.31	0.38	0.45	0.5	0.57	0.70	
	Struck	m ³	0.20	0.23	0.28	0.35	0.38	0.43	0.50	
Opening width	With side cutter	mm	590	700	800	915	1,000	1,100	—	
	Without side cutter	mm	500	600	700	815	900	1,000	1,150	
No. of teeth			3	3	4	4	5	5	5	
Bucket weight			kg	280	300	340	360	380	400	410
Combination	2.38 m standard arm		○	○	○	○	◎	△	△	
	2.84 m long arm		○	○	◎	△	×	×	×	

◎ Standard ○ Recommended △ Loading only × Not recommended

Travel System

Travel motors	2 × Axial piston, two speed motors
Parking brakes	Oil disc brake per motors
Travel shoes	40 each side
Travel speed	4.8/2.4 km/h
Drawbar pulling force	196 kN (ISO 7464)
Gradeability	70 % {35 deg}
Ground clearance	455 mm

Cab & Control

Cab	
All-weather, sound-suppressed steel cab mounted on the silicon-sealed suspension mounts and equipped with a heavy, insulated floor mat.	
Control	
Two hand levers and two foot pedals for travel	
Two hand levers for excavating and swing	
Electric rotary-type engine throttle	
Noise levels	
External	95 dB (A)
Operator	69 dB (A)

Boom, Arm & Bucket

Boom cylinders	100 mm x 1,092 mm
Arm cylinder	115 mm x 1,120 mm
Bucket cylinder	95 mm x 903 mm

Dozer Blade

Dozer cylinder	114 mm x 210 mm
Dimensions	3,260 mm (width) x 815 mm (height)
Working ranges	790 mm (up) x 600 mm (down)
Max. tilt height	445 mm
Angle	25 degrees

Refilling Capacities & Lubrications

Fuel tank	190 L
Cooling system	9.0 L
Engine oil	13.0 L
Travel reduction gear	2 x 5.0 L
Swing reduction gear	1.65 L
Hydraulic oil tank	79.3 L tank oil level
	168.0 L hydraulic system
DEF/Urea tank	33.9 L

Working Ranges

Unit: m

MODEL	ED160 Blade Runner	
Boom	4.68 m	
Arm length	Standard 2.38 m	Long 2.84 m
a- Max. digging reach	8.34	8.78
b- Max. digging reach at ground level	8.16	8.61
c- Max. digging depth	5.36	5.82
d- Max. digging height	9.34	9.71
e- Max. dumping clearance	6.90	7.26
f- Min. dumping clearance	2.74	2.38
g- Max. vertical wall digging depth	4.73	5.29
h- Min. swing radius	2.00	2.40
i- Horizontal digging stroke at ground level	4.23	4.72
j- Digging depth for 8' (2.4 m) flat bottom	5.13	5.63
Bucket capacity (ISO heaped)	0.5 m ³	0.38 m ³

Digging Force (ISO 6015)

Unit: kN {kgf}

Arm length	Standard 2.38 m	Long 2.84 m
Bucket digging force	90.1 {9,190}	89.3 {9,110}
Arm crowding force	64.4 {6,570}	58.1 {5,920}

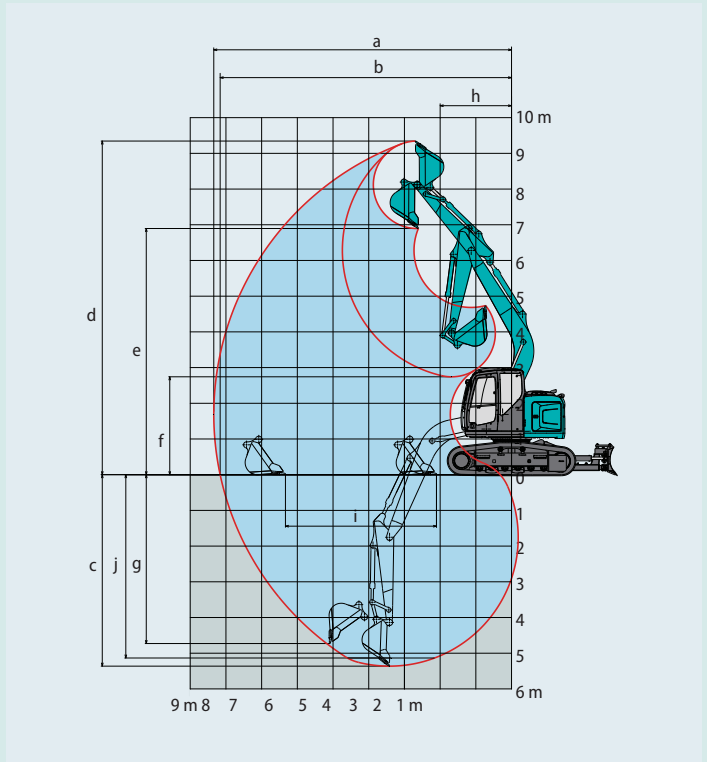

Dimensions

Arm length	Standard 2.38 m
A Overall length	8,530
B Overall height (to top of boom)	3,030
C Overall width of crawler (with 600 mm shoe)	2,590
D Overall height (to top of cab)	3,030
E Ground clearance of rear end*	1,010
F Ground clearance*	455

Unit: mm

G Tail swing radius	1,490
G' Distance from center of swing to rear end	1,490
H Tumbler distance	2,800
I Overall length of crawler	3,600
J Track gauge	1,990
K Shoe Width	600
L Overall width of upperstructure	2,490
M Overall width (blade wings extended)	3,260
N Folding blade width	2,460

*Without including height of shoe lug

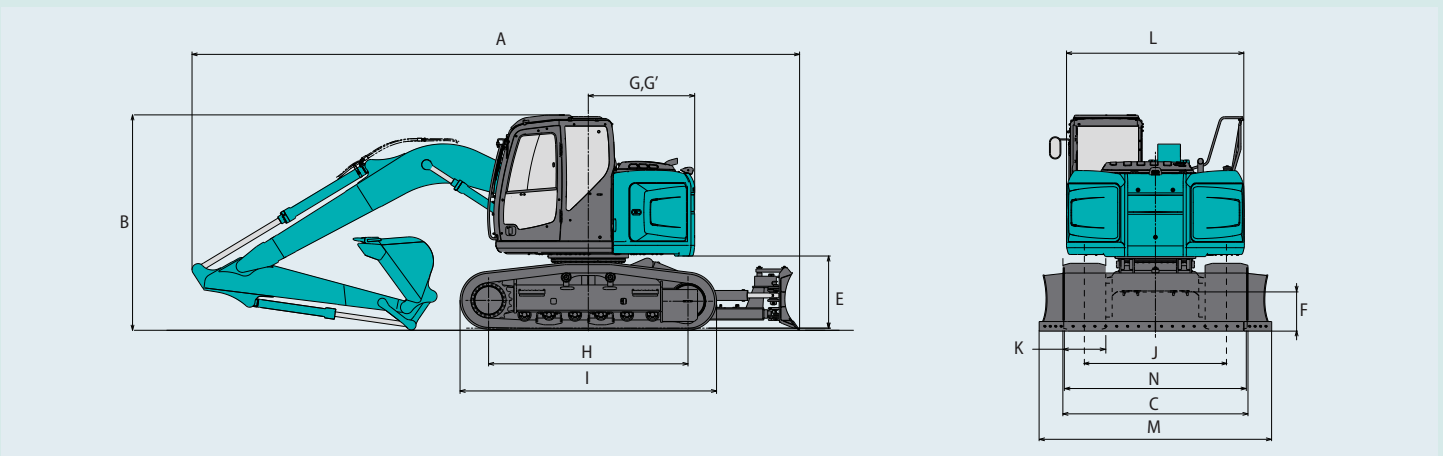

Operating Weight & Ground Pressure

In standard trim, with standard boom, 2.38 m arm, and 0.5 m³ ISO heaped bucket

Shaped		Curved triple grouser shoes		
Shoe width	mm	500	600	700
Overall width of crawler	mm	2,490	2,590	2,690
Ground pressure	kPa	51	43	38
Operating weight	kg	16,000	16,300	16,500

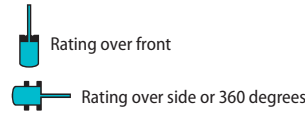
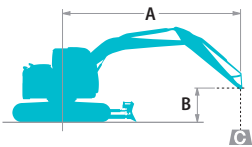

A – Reach from swing centerline for arm top
 B – Arm top height above/below ground
 C – Lifting capacities in kilograms
 * Max. discharge pressure: 34.3 MPa

ED160 Blade Runner		Standard Arm: 2.38 m		Bucket: without		Shoe: 600 mm						
A	B	1.5 m		3.0 m		4.5 m		6.0 m		At Max. Reach		Radius
		Front	Side	Front	Side	Front	Side	Front	Side	Front	Side	
7.5 m	kg									*2,190	*2,190	3.94 m
6.0 m	kg					*3,490	*3,490			*1,770	*1,770	5.61 m
4.5 m	kg			*4,540	*4,540	*3,810	3,660	2,620	2,290	*1,650	*1,650	6.52 m
3.0 m	kg			*6,840	6,370	4,030	3,420	2,530	2,210	*1,650	*1,650	6.99 m
1.5 m	kg			*5,320	*5,320	3,750	3,170	2,420	2,100	*1,750	1,630	7.11 m
G. L.	kg			*6,340	5,480	3,580	3,020	2,340	2,030	1,910	1,670	6.89 m
-1.5 m	kg	*5,550	*5,550	7,100	5,500	3,540	2,970	2,320	2,010	2,170	1,880	6.31 m
-3.0 m	kg	*9,140	*9,140	*6,160	5,630	3,610	3,040			2,900	2,490	5.23 m

- Do not attempt to lift or hold any load that is greater than these lifting capacities at their specified lift point radius and heights. Weight of all accessories must be deducted from the above lifting capacities.
- Lifting capacities are based on machine standing on level, firm, and uniform ground. User must make allowance for job conditions such as soft or uneven ground, out of level conditions, side loads, sudden stopping of loads, hazardous conditions, experience of personnel, etc.
- Arm top defined as lift point.
- The above lifting capacities are in compliance with ISO 10567. They do not exceed 87% of hydraulic lifting capacity or 75% of tipping load. Lifting capacities marked with an asterisk (*) are limited by hydraulic capacity rather than tipping load.
- Operator should be fully acquainted with the Operator's and Maintenance Instructions before operating this machine. Rules for safe operation of equipment should be adhered to at all times.
- Lifting capacities apply to only machine as originally manufactured and normally equipped by KOBELCO CONSTRUCTION MACHINERY CO., LTD.

STANDARD EQUIPMENT

ENGINE

- Engine, ISUZU AR-4J1XASK-01, Diesel engine with turbocharger and Intercooler (Stage IV-compliant engine)
- Auto idle Stop
- Automatic engine deceleration
- Batteries (2 x12V - 80 Ah)
- Starting motor (24 V - 5kW), 50 amp alternator
- Engine oil pan drain cock
- Double element air cleaner
- Refueling pump

CONTROL

- Working mode selector (H-mode, S-mode and ECO-mode)
- Extra N&B piping (proportional hand controlled)
- Object Handling Kit (boom and arm safety valves + hook)

SWING SYSTEM & TRAVEL SYSTEM

- Swing rebound prevention system
- Straight propel system
- Two-speed travel with automatic shift down
- Sealed & lubricated track links
- 600mm track shoes
- Grease-type track adjusters
- Automatic swing brake
- Dozer blade

MIRRORS, LIGHTS and CAMERAS

- Rear view mirrors
- Rear & right view camera
- Three front working lights (two for boom and one for right storage box)

CAB & CONTROL

- Two control levers, pilot-operated
- Horn, electric
- Integrated left-right slide-type control box
- Cab light (interior)
- Coat hook
- Large cup holder
- Detachable two-piece floor mat
- Retractable seatbelt
- Headrest
- Handrails
- Intermittent windshield wiper with double-spray washer
- Skylight
- Top guard (ISO 10262 : 1998)
- Tinted safety glass
- Pull-up type front window and removable lower window
- Easy-to-read multi-display monitor
- Automatic air conditioner
- Emergency escape hammer
- EU radio (AUX & USB & Bluetooth)
- 12V converter
- Air suspension seat with heater
- Remote machine monitoring system "KOMEXS"

OTHERS

- Lower under cover

OPTIONAL EQUIPMENT

- Various optional arms
- Wide range of shoes
- Front-guard protective structure (may interfere with bucket action)
- Mechanical suspension seat
- Cab additional light
- Rain visor (may interfere with bucket action)
- Travel alarm

Note: Standard and optional equipment may vary. Consult your KOBELCO dealer for specifics.

Note: This catalog may contain attachments and optional equipment that are not available in your area. And it may contain photographs of machines with specifications that differ from those of machines sold in your areas. Please consult your nearest KOBELCO distributor for those items you require. Due to our policy of continuous product improvements all designs and specifications are subject to change without advance notice. Copyright by **KOBELCO CONSTRUCTION MACHINERY CO., LTD.** No part of this catalog may be reproduced in any manner without notice.

KOBELCO CONSTRUCTION MACHINERY EUROPE B.V.

Veluwezoom 15
 1327 AE Almere
 The Netherlands
 www.kobelco-europe.com

Inquiries To: